



**MAKERS OF STAND AID
AND POWERTOILET AID**

STAND AID
MODEL 1503

PO BOX 386
Sheldon, IA 51201
1-800-831-8580
712-324-2153
Fax: 712-324-5210

**INSTRUCTIONS AND WARRANTY FOR THE
STAND AID MODEL 1503
STAND AID SERIAL # _____**

STAND AID INFORMATION
OPERATING INSTRUCTIONS
REPLACEMENT PARTS

READ complete manual
CAREFULLY BEFORE
attempting operation.

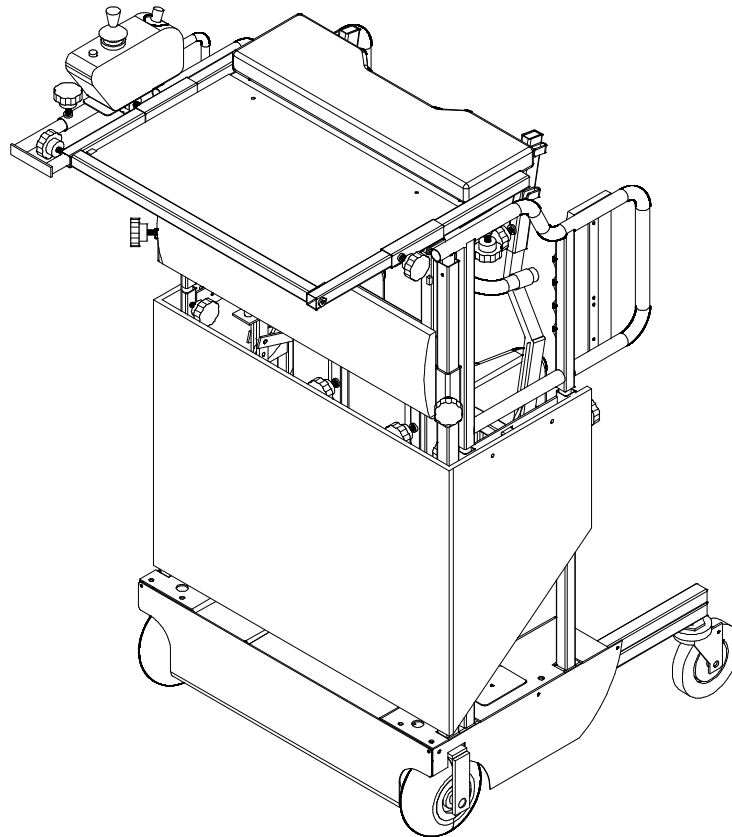

CAUTION:

All Stand Aid models should be used only on level, smooth surfaces. Please exercise caution and good judgement when operating your unit.

INTRODUCTION

Thank you and congratulations on your purchase of the STAND AID Model 1503. We are certain the benefits you receive from standing with our Stand Aid will enhance your health and outlook on life.

GENERAL INFORMATION

After unpacking your Stand Aid, place any parts that are not attached to the Stand Aid on the floor, using the parts list to get familiar with the unit and parts. On the standard Stand Aid there should be no tools needed to adjust the unit for your standing pleasure. Check your packing list for the options that came with your unit.

Parts included in the standard unit, 1 – Safety Belt, 2 – Heel straps, 1 – Toe Strap, 1 – 4” Safety Gate Pad, and 1 – 2” Safety Gate Pad.

All Stand Aid models should be used only on level, smooth surfaces. Please exercise caution and good judgement when operating your unit.

Quick Overview of Standing Instructions

1. Place sling under buttocks securely.
2. Adjust frame to desired height, making sure all knobs are tight.
3. Make sure table is adjusted high enough so the lift arms do not hit the table.
4. Move whatever you are being lifted out of to the rear of the Stand Aid.
5. Open Safety Gate, place your feet onto the floor of the Stand Aid in the Heel Straps and Toe Straps. Bring Lift Arms down to your lap, and place the Slings D-ring onto the Lift Arm Hook Slides, making sure they are secure on the Slides.
6. Run Lift Arms up slowly, make sure the sling is under the buttocks correctly, for first time users go up slowly until you are at a vertical position
7. After you are in the up position, close the Safety Gate into the locked position.
8. **Stand Aid recommends that you have someone there when you are standing for the first time.**

WHEN CALLING FOR SERVICE PLEASE HAVE THE SERIAL NUMBER OF YOUR UNIT READY FOR THE STAND AID REPRESENTATIVE. THIS WILL HELP IN THE SERVICING OF YOUR STAND AID PRODUCT.

STAND AID MODEL 1503
STANDARD FRAME
WITH “POWER LIFT AND DRIVE”

TABLE OF CONTENTS

Cover	Page #1
Introduction and General Information.....	Page #2
Table of Contents	Page #3
Limited Warranty Information	Page #4
Getting to know your Stand Aid	Page #5
Safety Precautions.....	Page #6
Preventive Maintenance & Repair.....	Page #7
Parts Breakdown and Part List.....	Pages #8-9
Safety Gate and Back Support Options	Pages #10-11
Battery Installation	Page #12
Battery Charging Information	Page #13
Operating Instructions.....	Pages #14,15
Additional Options and Safety Switch	Page #16
Operating Drive Control	Page #17
Drive Control Information	Page #18
Drive Control Care	Page #19
Stand Aid Part Ordering Policies	Page #20

LIMITED WARRANTY

Each Stand Aid of Iowa, Inc. product has been carefully inspected and tested before shipment. Accordingly, we warrant each STAND AID which is sold against defects in workmanship and material under normal use for life, excluding the motor, drive train and electrical components which are warranted for 1 year and the batteries which are warranted for 90 days. This warranty shall not extend to and we shall have no responsibility with respect to products which have been abused, misused, altered or as to which repair has been made or attempted by others.

This warranty is made in lieu of all other warranties with respect to the product covered hereby and there are no other warranties, whether expressed or implied, of merchantability or otherwise, except the warranty expressly stated herein. The remedy set forth herein shall be the sole exclusive remedy of any purchaser with respect to any defective product. Under no circumstances shall STAND AID of IOWA be liable for any injury, loss, damage or expense suffered or incurred with respect to any misuse of STAND AID of IOWA'S products.

If you have any questions or need further information, please feel free to call our offices at: 1-800-831-8580.

ATTENTION: IMPORTANT!

We ask that you take time to acquaint yourself with your Stand Aid, it's adjustments and controls. We highly recommend that someone assist you as you familiarize yourself with the unit.

Again, we remind you to use your Stand Aid only on level, smooth surfaces.

INSTRUCTIONS FOR STAND AID MODEL 1503

Remove the table from the lower half of the Stand Aid unit and place it in the table mounting bracket. Remove the safety gate pads that are packed behind the table.

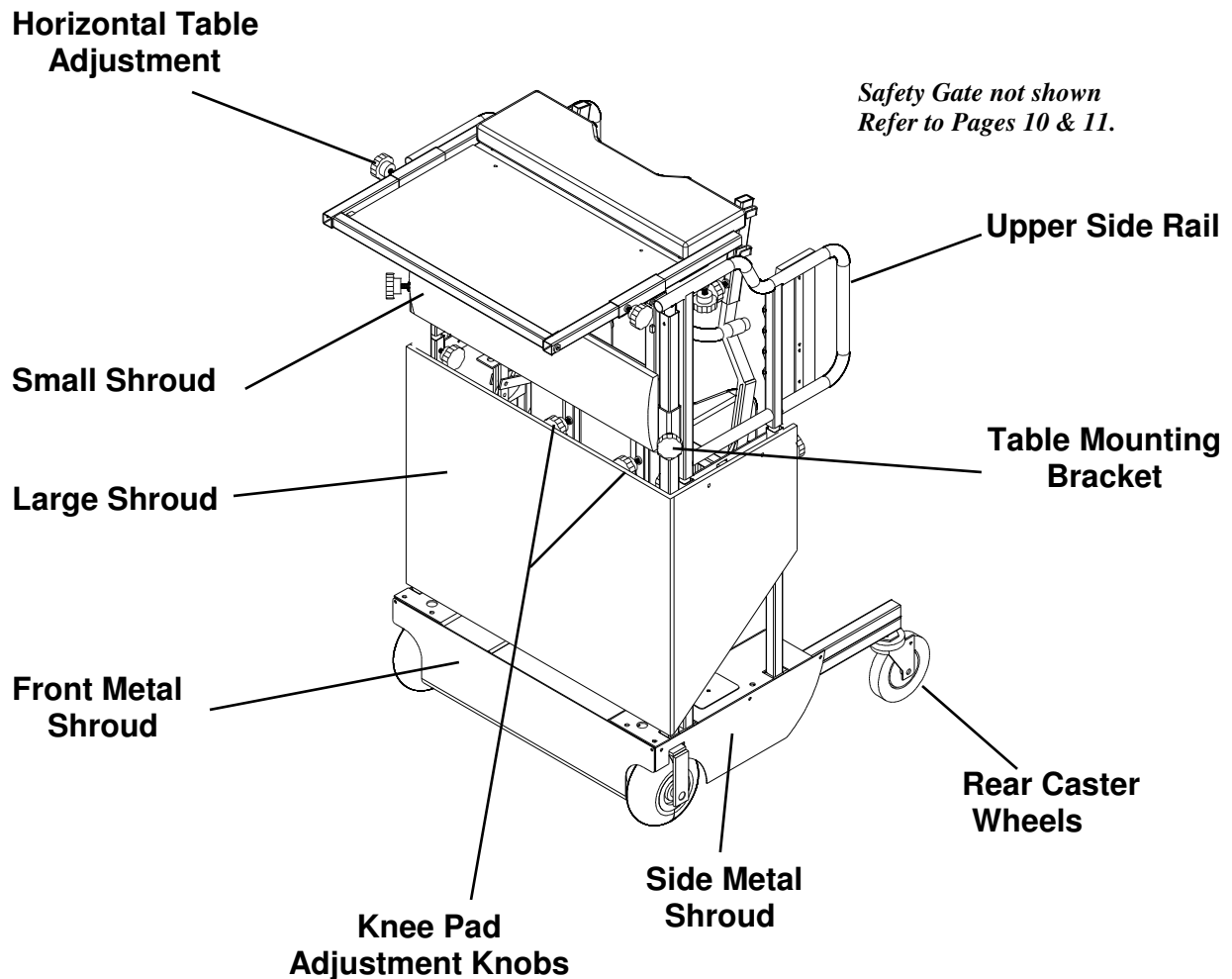

SAFETY PRECAUTIONS

READ THIS BEFORE OPERATING YOUR UNIT!!!!

1. If at all possible have an attendant help you with the first several stands, to help with adjustments of the unit for your comfort and safety.
2. Always use on a level and smooth surface.
3. Never operate the unit if it appears damaged.
4. Never operate the unit if it is not operating correctly, consult our service department.
5. Never raise or lower the lift with hands on or by the lift arms or lift arm linkage.
6. Keep all body parts away from moving parts on the unit at all times.
7. Always keep younger children away from this unit. Never allow younger children to operate this unit.
8. Always try to keep the unit in proper working condition.
9. Replace Battery if it is damaged or leaking, dispose of damaged battery.
10. When Stand Aid is not in use always unplug the power source from the battery (1501) or batteries (1502 & 1503).
11. Always make sure that the sling is positioned correctly under the buttocks and the D-rings of the sling are on the lift hooks properly.
12. Always unplug the key from the Stand Aid when unit is not in use.
13. Never operate the Stand Aid lift arms while the Safety gate is in the locked position.
14. Never run the lift switch and safety switch at the same time.

PREVENTIVE MAINTENANCE AND REPAIR

- Keep all electrical connections clean and dry.

Do not allow joystick or control module to become exposed to moisture.

For the following lubrications, we recommend that you carefully tip the Stand Aid forward, laying it face down on the floor. The power drive sprocket, and chains are located under the floor base.

Lubricate power drive sprockets with one shot of grease every six months. Clean and lightly lubricate drive chains with lightweight oil. (see picture below)

If the lift and/or drive unit operates slowly, charge the batteries for 18-24 hours. If the unit still operates slowly, you may need to change batteries. Replacement batteries may be ordered by calling Stand Aid of Iowa at 1-800-831-8580.

CAUTION!! DO NOT OPERATE YOUR STAND AID LIFT ARMS WHILE CHARGING THE BATTERY!!

If one or both of the lift arms fail to operate, check all electrical connections by disconnecting, cleaning and reconnecting. If this does not remedy the situation, call 1-800-831-8580 and ask for the service department.

For any other repairs, maintenance or trouble shooting, please feel free to call during regular business hours from 7:00 A.M. to 5:00 P.M. CST.

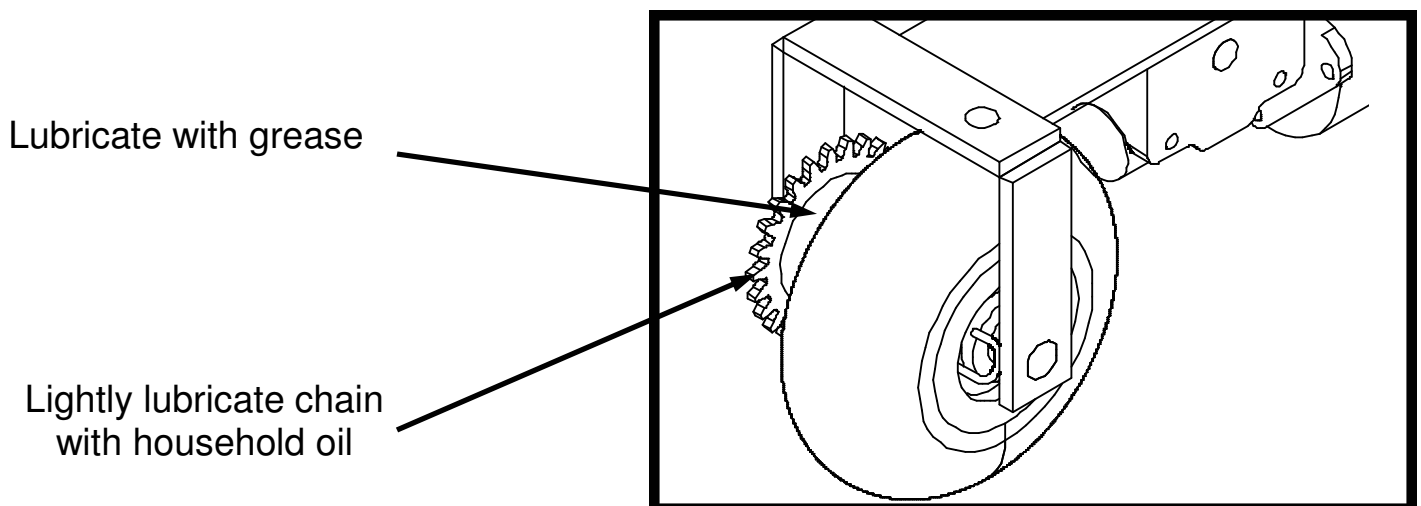

PARTS BREAKDOWN

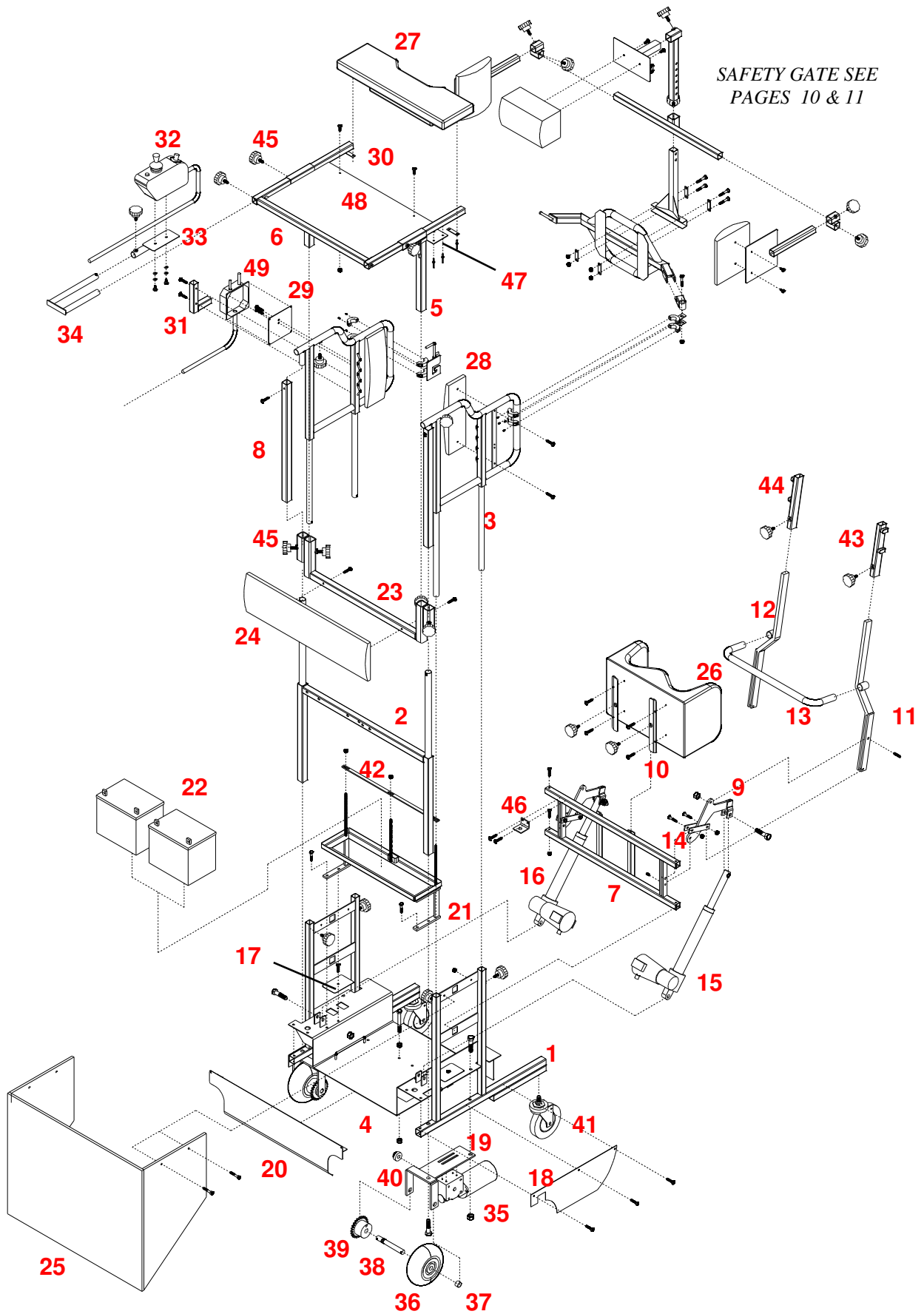

STAND AID MODEL 1503 PARTS LIST

REF. #	PART #	QTY.	DESCRIPTION
1.	85002002	1/1	Lower Side Rt./Lt.
2.	85002003	1	Lower Front
3.	85002000	1/1	Upper Side Frame Rt./Lt.
4.	85002007	1	Floor Pan
5.	85002019	1/1	Table Hinge Rt./Lt.
6.	85002004	1	Table Frame
7.	85002001	1	Knee Pad Bracket
8.	85002029	2	Front Corners
9.	85002020	2	A-Frame
10.	85002008	2	Knee Pad Slide
11.	82002002	1	Left Lift Arm
12.	82002040	1	Right Lift Arm
13.	85002015	1	Stabilizer Hold Bar
14.	85002011	4	Lift Linkage
15.	25003028	1	Left Actuator
16.	25003029	1	Right Actuator
17.	85002006	2	Chain Cover
18.	85002005	2	Side Shroud
19.	85002021	1/1	Power Drive Fork Rt./Lt.
20.	85002016	1	Front Shroud
21.	85002022	1	Battery Pan
22.	25003030	2	Battery
23.	85002009	1	Table Slide Bracket
24.	26003021	1	Small Top Shroud
25.	26003022	1	Large Bottom Shroud
26.	26003002	1	Knee Pad
27.	26003003	1	Table Pad
28.	26003023	2	Hip Pad
29.	85002024	1	Switch Plate
30.	85002013	2	Table Clip
31.	85002010	1	Lift Switch Guard
32.	25003024	1	Control
33.	85002025	1	Joystick Mount
34.	85002027	1	Joystick Slide
35.	25003025	1/1	Motor Rt./Lt.
36.	25003026	2	Drive Wheel
37.	85002030	2	Drive Wheel Spacer
38.	85002023	2	Drive Wheel Axle
39.	85002014	2	Drive Wheel Hub/Sprocket
40.	25003031	2	Motor Sprocket
41.	25003027	2	Caster Wheel
42.	85002012	1	Battery Tie Down Strap
43.	82002006	1	Left Lift Arm Slide Hook
44.	82002005	1	Right Lift Arm Slide Hook
45.	25003000	14	Adjustment Knob
46.	85002017	1	Safety Switch Mount
47.	85002018	1	Chest Pad Bracket
48.	82002017	1	Table Plexi Glass

REF. #	PART #	QTY.	DESCRIPTION
49.	25003033	1	Lift Switch Assembly
50.	26003007	2	Heel Strap <i>(not shown)</i>
51.	26003008	1	Toe Strap <i>(not shown)</i>
52.	26003024	1	Sling w/ rings <i>(not shown)</i>
53.	26003000	1	Rt. Slide Hook Cover <i>(not shown)</i>
54.	26003001	1	Lt. Slide Hook Cover <i>(not shown)</i>
55.	25003032	2	Drive Chain <i>(not shown)</i>
56.	25003034	1	Safety Lift Switch <i>(not shown)</i>

Please order parts by **PART NUMBER**
and **DESCRIPTION**.

(optional) SAFETY GATE With BACK SUPPORT

The “SAFETY GATE” easily attaches to the frame of the Stand Aid to give you added support. One four-inch pad and one two-inch pad will accompany the Safety Gate. It will depend on the physical build of the user as to what pad will be used. These pads are placed on the Safety Gate for comfort and security. This latch can be mounted on either side of the Stand Aid.

The “SAFETY GATE BACK SUPPORT” can also be added for those requiring more back support. This attachment easily clamps onto the Safety Gate.

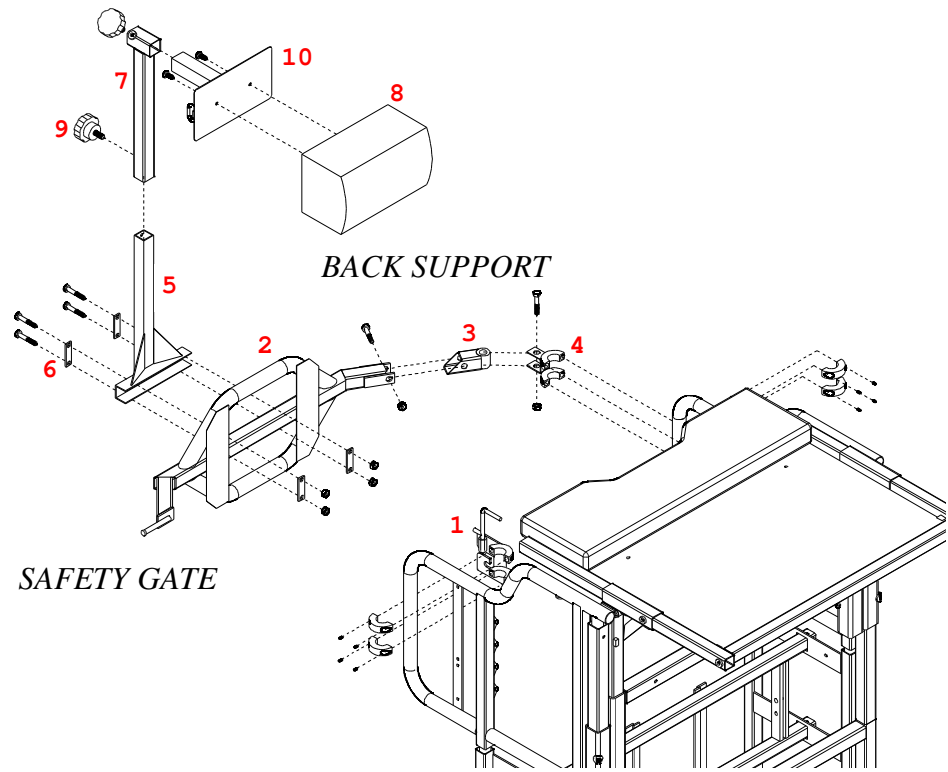

Parts List

REF. #	PART #	QTY.	DESCRIPTION
1.	8213-2025	1	Safety Gate Lock
2.	8210-2026	1	Safety Gate
-	2600-3009	1	Safety Gate Pad (not shown)
3.	8211-2023	1	Swivel Hinge
4.	8212-2024	1	Gate Mount
5.	8200-2036	1	Back Support Mount
6.	8200-2045	4	Back Support Mount Links
7.	8226-2022	1	Back Pad Mount/Adjust
8.	2600-3010	1	Back Support Pad
9.	2500-3000	4	Adjustment Knob
10.	8225-2034	1	Top Pad Mount

Assembly Instructions

1. Attach the safety gate assembly (#2, #3 , & #4) Left or Right by tightening the gate mount (#4) clamps around tube. Height adjustment may be required later.
2. Mount the back support mount (#5) to the safety gate using the mounting strips (#6), and 1/4" x 1-1/2" bolts.
3. Assemble the back pad (#8) to the back pad mount (#10) with 10-24 x 1/2" bolt. Slide this assembly into the back pad adjust (#7), and then over the back support mount (#5), secure at the desired position with the adjusting knobs (#9).

(optional) SAFETY GATE LATERAL BACK SUPPORT

The “SAFETY GATE and LATERAL BACK SUPPORT” can also be added for those requiring more back support. This attachment easily clamps onto the Safety Gate and comes with an extra safety belt to hold the upper body snug against the back rest. This Kit includes the Safety Gate kit without the standard back support. The standard back support is replaced with the back support below.

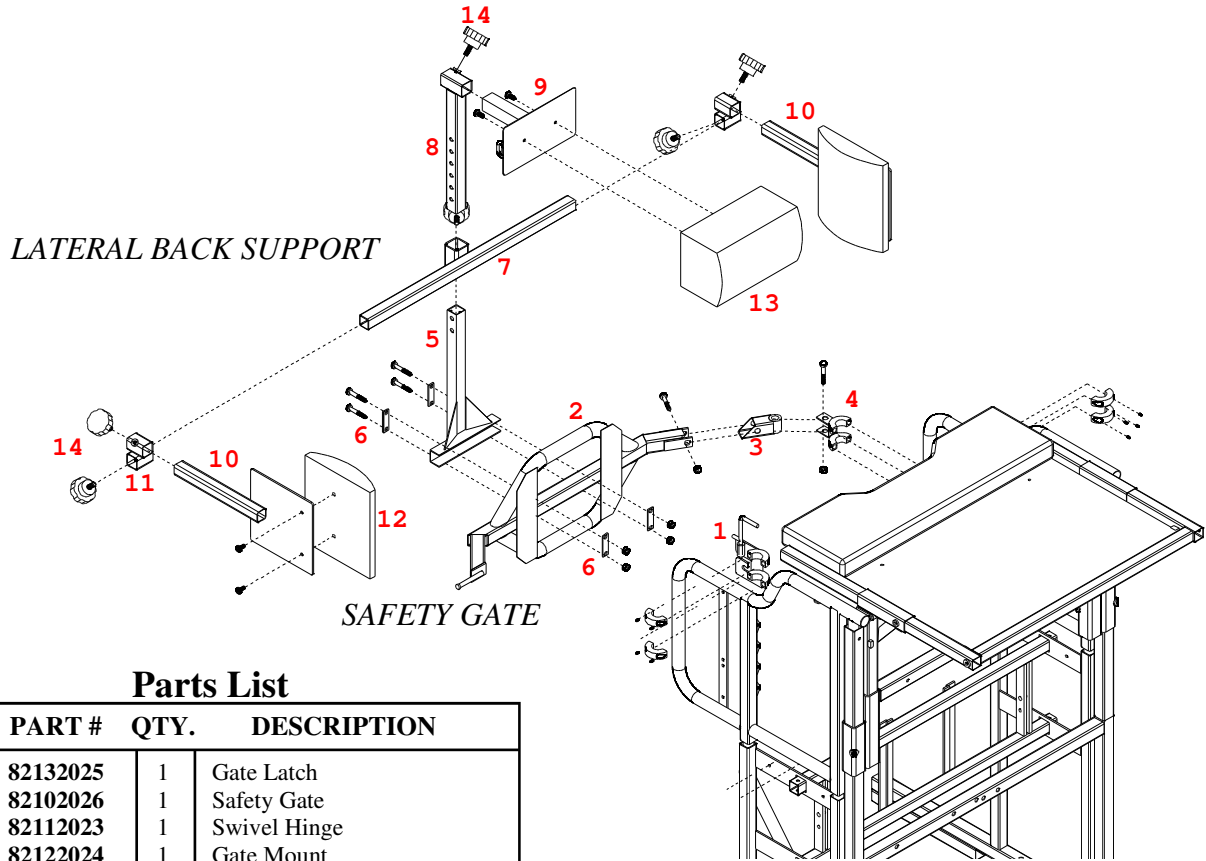

Parts List

REF. #	PART #	QTY.	DESCRIPTION
1.	82132025	1	Gate Latch
2.	82102026	1	Safety Gate
3.	82112023	1	Swivel Hinge
4.	82122024	1	Gate Mount
5.	82202029	1	Back Support Mount
6.	82002045	4	Back Support Mount Links
7.	82222031	1	Back Support Adjust
8.	82212030	1	Back Support Vertical Slide
9.	82252034	1	Back Pad Mount
10.	82002038	2	Outside Pad Mount
11.	82002037	2	Slide Adjust
12.	26003012	2	Outside Wide Pad
13.	26003010	1	Back Support Pad
14.	25003000	6	Adjustment Knob
15.	25003011	1	1/4" Lock Pin (not shown)

- Assemble the back support adjustment assembly (#5, #7, & #8) by sliding the tubes together, #8 slides into #7, and slides over the back support mount (#5), attach using lock Pin (#16). Secure the adjusting knob (#15) at desired height. Attach this assembly to the safety gate using the mounting strips (#6) and 1/4" X 1-1/2" bolts and locknuts.
- Attach the back pad (#13) to the back pad mount (#9) with 10-24 x 1/2" bolt. Insert this assembly into the back support vertical slide (#8), and secure with the adjusting knob (#14).
- Attach the outside pads (#12) to the outside pad mounts (#10) using 10-24 x 1/2" bolts. Slide these assemblies onto the slide adjust (#11). Slide these assemblies onto the back support adjust (#7), and secure with the adjusting knobs (#14). Width adjustment may be required later.

Assembly Instructions

- Attach the safety gate assembly (#2, #3, & #4) to the frame by tightening the gate mount clamps around tube. Height adjustment may be required later.

BATTERY INSTALLATION/REPLACEMENT

IMPORTANT: UNPLUG BOTH POWER SOURCE PLUG CONNEC-
TO AVOID CONFUSION DISCONNECT AND REPLACE
ONE BATTERY AT A TIME

Begin by removing the upholstery large shroud that covers the front and sides of your Stand Aid. This is done by removing the the four small bolts located on the sides of the shroud.

Remove the three nuts that secure the battery tie down strap, located on the top of the batteries.

Red wire leads connect to the positive "+" terminal post. Black wire leads connect to the negative "-" terminal posts. Change batteries, and retighten all battery post connections. Replace the shroud, and connect the power source plugs.

<p>IMPORTANT: CHARGE NEW BATTERIES FOR 10-12 HOURS BEFORE USING</p>
--

BATTERY CARE AND MAINTENANCE

Proper care of your battery will insure a long life and trouble free service. Stand Aid uses a gel cell battery that **DOES NOT** require water and will not emit harmful vapors when charging.

If you use your lift unit extensively on a daily basis, charge your battery 2-3 times per week for 8-10 hours per charging session.

If you put your Stand Aid in storage the batteries should be fully charged and recharged every 45 days. Never let your batteries go completely dead. Keep the batteries dry and do not lay any object on top of them.

In order to charge your battery; simply plug the charger into any standard wall receptacle.

**CAUTION!!! DO NOT OPERATE YOUR STAND AID
LIFT ARMS WHILE CHARGING THE BATTERY!!**

CHARGING WITH THE SONEIL (#1408S-C1)

L.E.D. INDICATOR

1. **RED:** Power Is On.
2. **YELLOW/ORANGE:** Charging
3. **GREEN:** Full Charge
4. **GREEN "FLASH":** Output Is Not Connected.

CHARGING PROCESS

FOR THE STAND AID MODEL 1503, PLUG THE POWER CORD INTO A WALL ELECTRICAL OUTLET, THE CHARGER IS LOCATED IN FRONT OF THE KNEE PAD. (SEE BELOW)

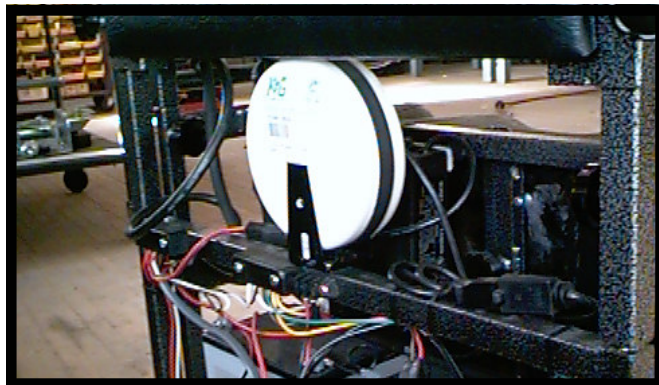

Please be advised that you can over-charge the battery. Stand Aid has changed the Battery Charger system. The current charger will give a slow trickle if the charger is left on the battery for a long period of time. Please use proper care, and try not to charge the battery more than 12 consecutive hours at one given time. This will help insure the battery's long life, and trouble free service.

IMPORTANT:

- NEVER CHARGE THE UNIT FOR MORE THAN 10-12 HOURS AT A TIME.
- NEVER OPERATE THE UNIT WHILE THE UNIT IS CHARGING.

OPERATING INSTRUCTIONS

Place the sling under your buttocks with the rings exposed on each side. Next, remove the footpads from your wheelchair and position the chair in the rear of the Stand Aid. Loosen the foot straps on the floor of the Stand Aid and place your feet on the floor. The strap that fits over the top of your instep should be snug but not tight. The heel straps should fit behind the heel to prevent the foot from slipping. Adjust the height of the kneepad so your knees are centered in the pad. The Kneepad may be adjusted by loosening the two black knobs behind the knee pad & positioning the pad correctly, then retighten the knobs.

The sling “D-rings” should slip easily onto the lift arm hooks . We recommend that the lift arm slide hook adjustment should be approximately midway between the hip and waist when you are in a standing position. After a few standing sessions, you will find the most comfortable setting for your slide hooks.

Once the sling “D-rings” are on the lift arm hooks, and sling correctly under your buttocks. Push the lift switch forward to lift yourself from the wheelchair to a standing position. Carefully lift yourself until your legs are straight and you feel comfortable. **IMPORTANT:** Exercise caution for the first several times you raise yourself to assure not only your safety, but your comfort as well. (refer to images below for visual reference.)

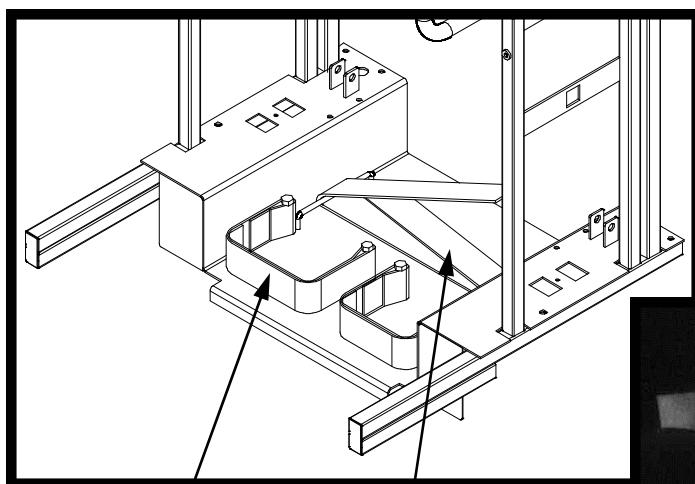

HEEL STRAP

TOE STRAP



Once you are in the upright position, close the safety gate behind you. And adjust the unit to the correct height by loosening the four knobs for upper side adjustment. Raise or lower the upper side rails of the Stand Aid until the safety gate is supporting the lower half of the buttocks. Retighten all knobs. This adjustment is important to ensure that your buttock does not slide under the safety gate. If further adjustment is necessary you can move the safety gate and latch using a 3/16" allen wrench on the allen head screws. Use either one of the safety gate pads or both to support your buttocks against the safety gate. The velcro strips will keep the pads in place.

The table height adjustment is important for upper body positioning. The chest pad should be positioned near the bottom of the sternum, the point on your rib cage where your bottom two ribs meet. In order to maintain correct posture, the table may be adjusted in or out in order to align the upper and lower portions of your body. The safety belt hooks to the rings located under each side of the table frame just ahead of the chest pad.

Now that most adjustments have been made, check and retighten all knobs to ensure that your Stand Aid will remain in the proper position. To lower yourself, simply release the safety belt, open the safety gate and use the lift switch to let yourself down. (refer to diagram below.)

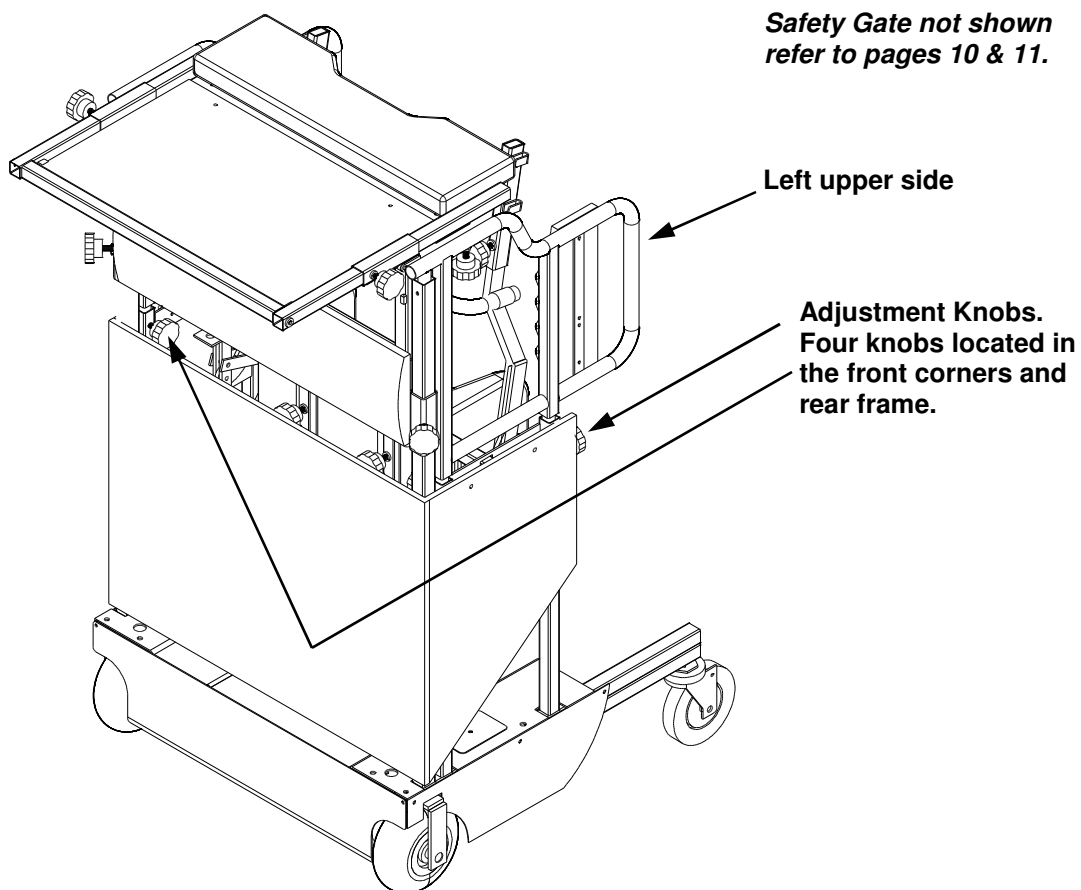

STAND AID ADDITIONAL OPTIONS

- Safety gate back support for those requiring more back support. (see page 10.)
- To accommodate larger wheelchairs, we offer caster brackets.
- Joystick bracket extension allowing the joystick to be placed in the center of the table.
- For your safety and comfort, we carry a large selection of sling sizes.
- The lift kit option is available to those who wish to convert their 1502 Stand Aid to a model 1503 Lift and drive.
- Lateral support for more upper body support.

For any other special options or modifications, please feel free to call and ask for the engineering department at **1-800-831-8580**.

STAND AID SAFETY SWITCH

Stand Aid of Iowa has added a safety switch to the 1503 model. This switch is located in front of the knee pad and to the right; it is silver in color. The safety switch will allow the user to operate the lift mechanism on the Stand Aid, **ONLY** if the main lift switch fails, or will not operate while user is standing! If you experience problems with the main switch, use the back up switch, and call for a replacement **IMMEDIATELY**. This back up switch is intended to be a safety feature and not for everyday use.

Never run both the lift switch and the safety switch at the same time! This will cause electrical failure.

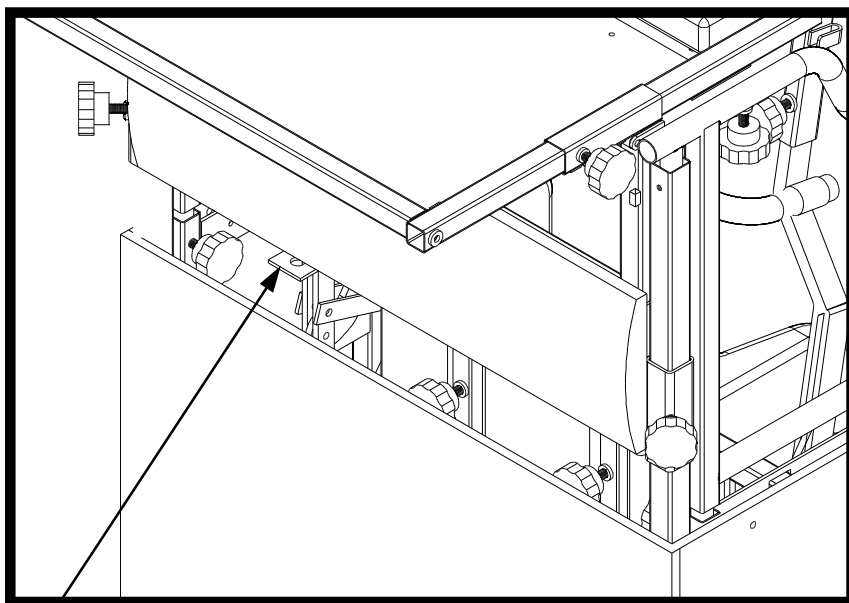

SAFETY SWITCH
(EMERGENCY USE ONLY)

OPERATING THE DRIVE CONTROLS

The joystick control for your drive unit may be located in several positions. It can be located on the upper side rails on either side of the unit as shown below. It is most commonly located on the table frame by simply removing the black plastic plug and inserting the control mount tube into the end of the table frame tube. It can also be adjusted in or out, up or down by loosening the two black knobs, and adjusting the control to your comfort.

The movement and direction of the frame is controlled by moving the joystick lever in the desired direction of travel. The joystick control is equipped with an on/off button, battery power indicator, and speed control.

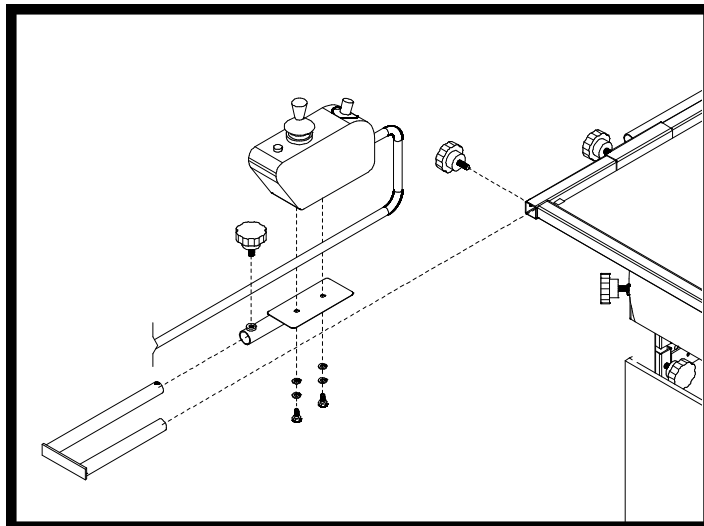

DRIVE CONTROLLER

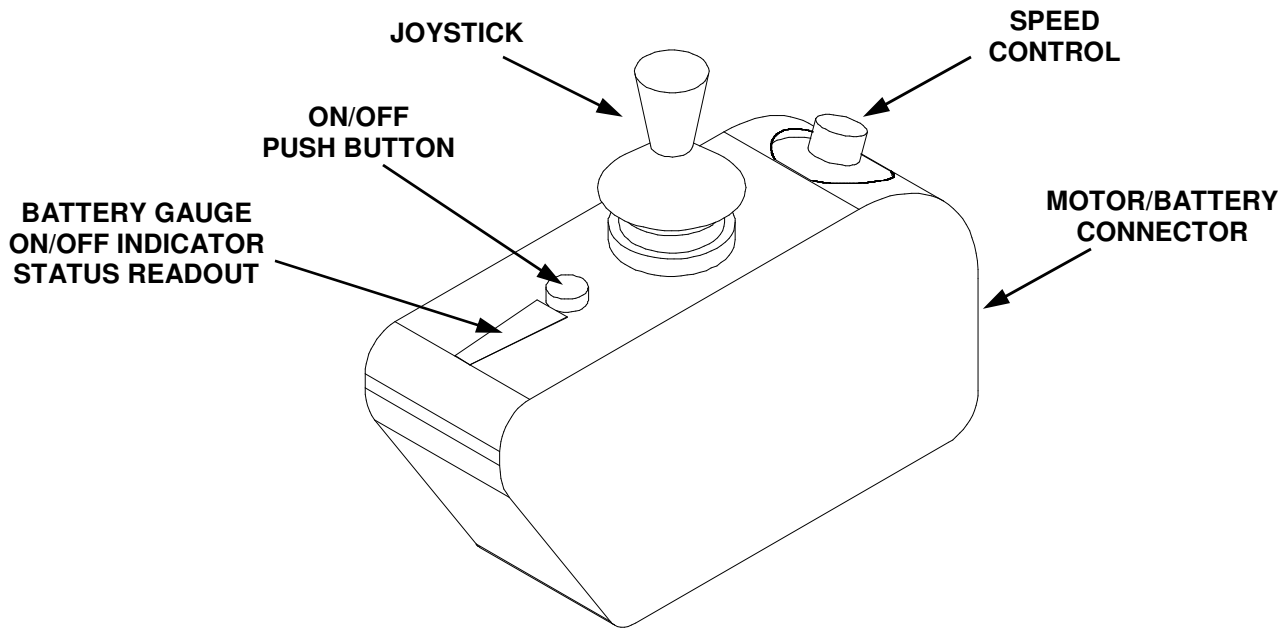

CONTROLS

ON/OFF PUSH BUTTON

This is a green push button switch fitted in front of the joystick which turns the controller on and off. Do not use this switch to stop the unit except in an emergency.

TRUCHARGE BATTERY GAUGE

This is a ten segment illuminated display which indicates if the controller is turned on and also gives the status of the battery, the controller and the units electrical system.

Red, yellow and green bars lit: Battery charged; controller and electrical system OK.

Red and yellow bars lit: Charge battery if possible; controller and electrical system OK.

Red bars only, lit or slow flash: Charge battery as soon as possible; controller and electrical system OK.

Rapid flash of bars: Indicates a fault in the controller or electrical system. See below for fault diagnostics.

Ripple up and down of bars: Joystick displaced at turn on.

Fault Type		Description
The number of flashing Bars indicate the possible area of fault	G	High battery voltage
	R	Solenoid brake fault
	E	Possible controller fault
	N	Possible joystick fault
	Y	Charger connected
	E	Right motor wiring fault
	L	Right motor disconnected
	L	Left motor wiring fault
	O	Left motor disconnected
	W	Low battery voltage

Joystick

Controls the speed and direction of the unit. Push the joystick in the direction you wish to go. The further you push it, the faster the speed. Releasing the joystick stops the unit automatically.

Speed Control

Sets the maximum speed of the unit; clockwise to increase, counter clockwise to decrease.

CARE

General

Avoid knocking your controller, especially the joystick. When transporting your unit ensure that the controller is well protected. To prolong the life of the controller keep exposure to extreme conditions to a minimum. Always clean your controller if it becomes contaminated with food and drink. Use a damp cloth with washing liquid mixed with water. Do not use abrasive or spirit based agents.

Daily Checks

Joystick: With the controller switched off, check that the joystick is not bent or damaged and that it returns to center when you release it. If there is a problem do not use your unit and contact your service agent.

Weekly Checks

Electrical Brakes: This test should be carried out on a level floor with at least one meter clear space around the unit.

Switch on the controller. Check that after 1 second the battery gauge remains on or flashes slowly. Push the joystick slowly forwards until you hear the electrical brakes operate. The unit may start to move. Immediately release the joystick, you must be able to hear each electrical brake operate within a few seconds. Repeat the test three times, pushing the joystick backwards, left and right respectively.

Connectors: Check all connectors are secure, properly mated and free from damage.

Cables: Check condition of all cables for damage.

Joystick Gaiter: Check the thin rubber gaiter around the base of the joystick for damage or splitting. Check visually only, do not handle the gaiter.

Mounting: Make sure the controller is securely fixed to your unit. Do not over tighten any screws.

IMPORTANT: Precautions For Use

The Pilot controller has been designed with user's safety as the prime consideration. It incorporates many sophisticated self-test features which search for potential problems at a rate of 100 times per second. If the controller detects a problem either in its own circuits, or in the units electrical system, it may decide to halt the unit depending on the severity of the problem. The Pilot is designed to maximize the user's safety under all normal conditions.

In spite of its sophistication, the Pilot cannot take into account circumstances which put the unit or the controller outside of their specified operating conditions, and so it is important that the user follows the precautions below:

- 1) Do not drive the unit
 - a) beyond restrictions indicated in the units manual, for example maximum inclines.
 - b) in places or on surfaces where a loss of wheel grip could be hazardous.
 - c) if the controller or other crucial components are known to require repair.
- 2) Although the Pilot controller is designed and manufactured to be extremely reliable and each unit rigorously tested, possibility of a system malfunction always exists (however small the probability). Under some conditions of detected system malfunction, the controller must (for safety reasons) stop the Stand Aid instantaneously. If the physical impairments of the user are such that a sudden braking action could result in a fall from the unit, it is imperative that a restraining device such as seat belt be purchased and installed with the unit. Restraining devices should be used at all times when the unit is in motion.
- 3) Under strenuous driving conditions it is possible for the bottom and side case temperature of the Pilot controller to exceed 41 deg. The user should not touch the side or bottom of the controller under these circumstances.

WARNING: Penny & Giles accepts no liability for losses of any kind arising from unexpected stopping of the unit or improper programming of the controller or improper use of the unit or controller.

STAND AID OF IOWA, INC.

PART ORDER POLICIES

SHIPPING:

ALL PARTS WILL BE SHIPPED ACCORDING TO THE CUSTOMERS SPECIFICATIONS; UPS, GROUND, AIR, FEDERAL EXPRESS OR OTHER MEANS. THE CUSTOMER WILL BE BILLED ACCORDINGLY.

PAYMENT:

ALL PARTS WILL BE SHIPPED C.O.D. THEY MAY BE PAID WITH ANY MAJOR CREDIT CARD OR THEY CAN BE PRE-PAID. THIS WILL PERTAIN TO ANY ORDER UNDER \$300.00 UNLESS OTHER ARRANGEMENTS HAVE BEEN MADE.

RETURN GOODS:

PLEASE CALL STAND AID OF IOWA SERVICE DEPARTMENT FOR A RETURN AUTHORISATION NUMBER (RA#). WARRANTY PARTS AND EXCHANGE PARTS CAN BE RETURNED AT NO CHARGE. ALL OTHER PARTS WILL HAVE A 20% RESTOCKING FEE WITHIN THE FIRST 30 DAYS AFTER THE PURCHASE. AFTER 30 DAYS A 40% RESTOCKING CHARGE WILL BE THE RESPONSIBILITY OF THE CUSTOMER. ANY PART CUSTOM MADE TO THE CUSTOMERS SPECIFICATIONS WILL HAVE A 60% RESTOCKING FEE IF RETURNED WITHIN THE FIRST 30 DAYS. AFTER 30 DAYS ALL CUSTOMIZED PARTS CANNOT BE RETURNED. THE CUSTOMER WILL BE RESPONSIBLE FOR ANY SHIPPING COST BACK TO STAND AID WITH THE EXCEPTION OF WARRANTY AND EXCHANGED PARTS.

STAND AID SHIPPING AND SERVICE DEPT. 1-800-831-8580

STAND AID OF IOWA, INC.

PO BOX 386

SHELDON, IA 51201

1-800-831-8580

1-712-324-2153 (In Iowa)

FAX: 712-324-5210



MAKERS OF STAND AID AND ROLL AID

STAND AID

Model 1503

(Standard frame with "Power Lift and Drive")

THE FOLLOWING IS A COMPLETE DESCRIPTION OF THE STAND AID #1503.

STAND AID; electric lift, mobile stander. Brings person from seated position to a passive standing position and have mobility. Fully adjustable to accommodate persons 4'2" to 7 ft. tall and a weight capacity up to 400 lbs. Overall size is 27" square and 44" high. Constructed of steel, round and square. Table size is approximately 12"x 20" with plexiglass surface. Adjustable knee pad. Two balloon cushion non mar front power drive wheels, with two 5" caster rear swivel wheels. Battery operated hydraulic lift operation, switch operated. Adjustable lift arms for body height and weight. Drive is controlled and operated by a joystick, whole unit moves forward, backwards, and turns. Variable speed control (max speed 5 mph.). Automatic shut off after 90 seconds of non use. Operated by two 24 volt permanent magnet motors. Optional sling sizes. Silver vein powder coat finish. Total weight is 275 lbs.

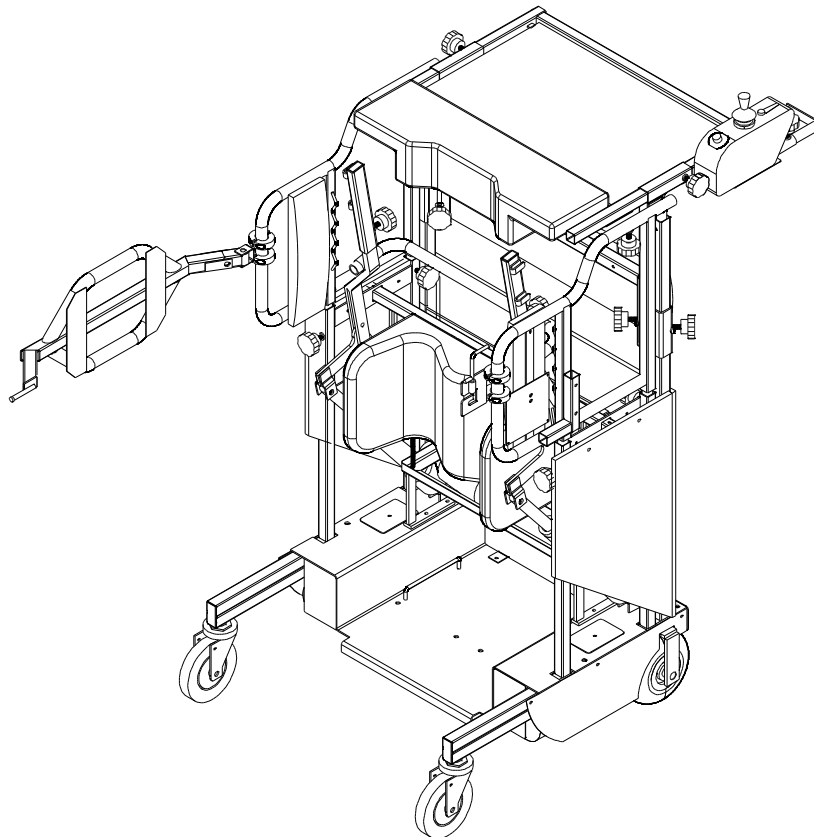

STAND AID OF IOWA, PO BOX 386 Sheldon, IA 51201

Phone: 1-800-831-8580 – (712)-324-2153

Fax: 712-324-5210